

AS 32 – 4Z

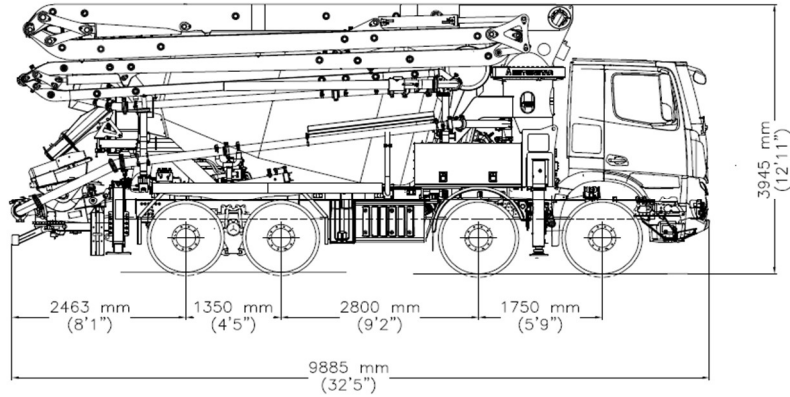

Note : Dimensions may vary depending on truck model.

PUMP	AS 32.70 4Z
Theo. Conc. Output(max) (Piston Side)	70 m ³ / h (91,55 yd ³ / h)
Theo. Conc. Pressure(max) (Piston Side)	81 bar (1174,80 psi)
Stroke	28 Stroke / min
Concrete Cylinder Dimensions	230 mm X 1000 mm (9,05" 39,37")

STANDART EQUIPMENT	
Hopper Capacity	: 450 lt (119 gal)
Switching System	: Electromagnetic Sensor
Concrete Valve	: S Valve System
Electric Box	: IP65 PLC Controlled
Remote Control	: HBC Remote Control
End Hose	: 3 m (9' 10") 4" Diameter
Water Tank Capacity	: 500 lt (132 gal) and Hose 15 m (49' 2")
Lubrication System	: Electrically Controlled Central System (LINCOLN)

BOOM SYSTEM	
Boom Type	: Z
Sections	: 4
Boom Swing Speed	: 116 sec
Boom Swinging Angle	: 365°
Concrete Pipe Diameter	: 100 mm (3,93")

SUPPORT LEGS SYSTEM	
Front Legs	: X
Rear Legs	: Fixed

MIXER SYSTEM	
Nominal Capacity	: 9 m ³
Drum Speed	: 1-14 rpm
Filling Ratio	: %73

CONTROL SYSTEM	
■ Smartstar Control	
■ Color LCD	
■ IP69K Electronic Keypad	
■ Diagnostic	
■ Fuel Saving Mode	
■ Switch Failure Mode	
■ Automatic Power Regulation	
■ Automatic Mixer	
■ Mixer Safety Switch	
■ Automatic Concrete Pumping	

OPTIONS	
■ Hopper Vibrator	
■ Hydraulic Driven Fan	
■ Stability Control	
■ Air Compressor	
■ End Hose Squeezer	
■ High Pressure Cleaning Kit (160 bar / 2320 psi)	
■ Betonstar IoT System	
■ Auto Unfolding	
■ Water and Oil Tank Heater	
■ Water Pump Hydraulic Operated	
■ Concrete Level Sensor	

BOOM WORKING DIAGRAM

