

MTP 20.16 D

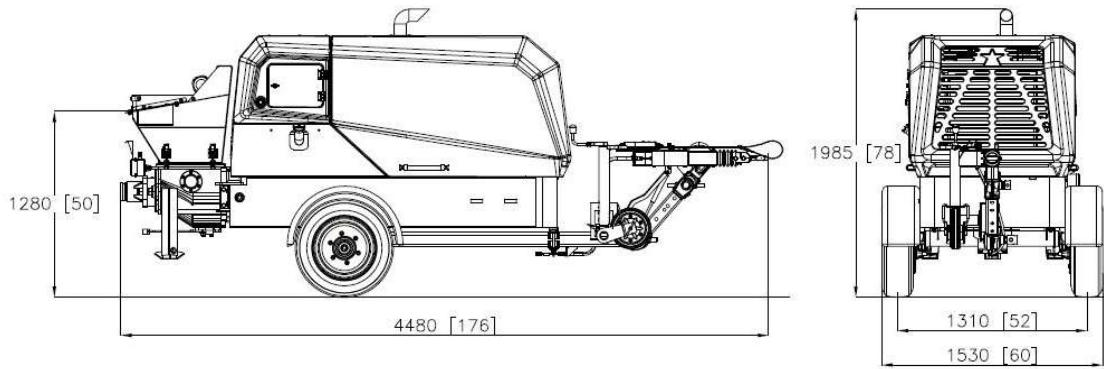

GENERAL

Weight : 2295 kg (5059 lbs)

ENGINE*

Power : 44.5 kW (60 hp) (Diesel)

PUMPING UNIT

Theo. Conc. Output(max)	: 21 m ³ /h (27,46 yd ³ /h)
Theo. Conc. Pressure(max)	: 80 bar (1160 psi)
Stroke	: 29 Stroke/min
Drive Cylinder Diameter	: 80/45 mm (3,15"/1,77")
Delivery cylinders diameter	: 150 mm (5,9")
Delivery cylinders stroke	: 700 mm (2'4")
Hopper capacity	: 250 L (66 gal)
Hopper outlet diameter	: 100 mm (3,93")
Maximum particle size	: 16 mm (0,63")
Switching System	: Electromagnetic Sensor
Lubrication System	: Elect. Controlled Central Sys. (LINCOLN)
Electric Box	: IP65 PLC Controlled

CONTROL

- Smartstar Control
- Color LCD
- Diagnostic
- Fuel Saving Mode
- Remote Control
- I/O Module (CANOpen)

OPTIONS

Power	: 3.1 kW
■ High pressure cleaning kit	Water pressure : 160 bar (2320 psi)
	Water flow : 10.6 lt/min
	Hose reel : Automatic hose reel
■ Hopper vibrator	

ENGINE CONTROL SYSTEM

- Regeneration Control
- Engine Diagnostics
- EOL Control System

(*) Engine power and norm values vary according to the engine brand.