

BST 51 – 5RZ

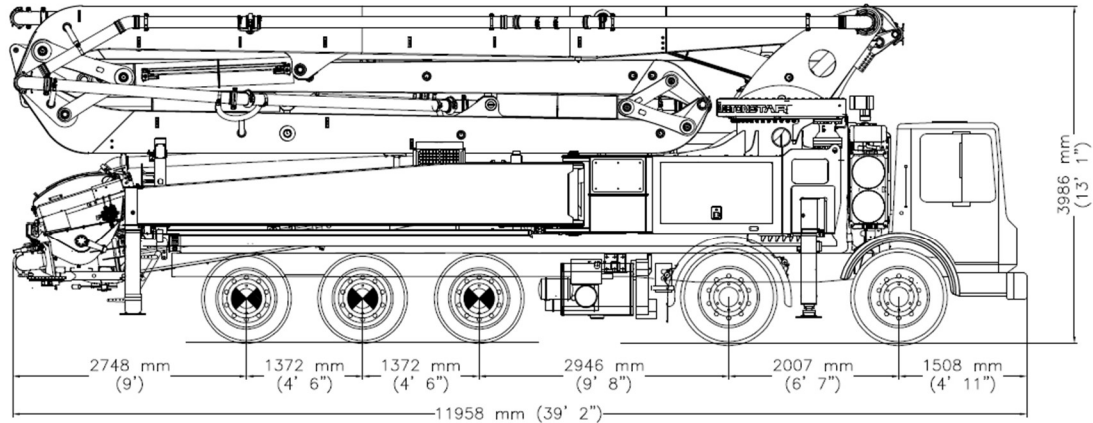

Dimensions may vary depending on truck model.

PUMP	BST 51.16 5RZ (OPT.)	BST 51.20 5RZ (STD.)
Theo. Conc. Output(max) (Piston Side)	160 m ³ / h (209,27 yd ³ / h)	200 m ³ / h (261,59 yd ³ / h)
Theo. Conc. Pressure(max) (Piston Side)	85 bar (1232,82 psi)	85 bar (1232,82 psi)
Stroke	26 Stroke / min	27 Stroke / min
Concrete Cylinder Dimensions	250 mm x 2100 mm (9,84" 82,68")	250 mm x 2500 mm (9,84" 98,42")

STANDART EQUIPMENT

Hopper Capacity	: 650 lt (172 gal)
Switching System	: Electromagnetic Sensor
Concrete Valve	: S Valve System
Electric Box	: IP65 PLC Controlled
Remote Control	: HBC Remote Control
End Hose	: 3 m (9' 10") 4" Diameter
Water Pump	: 67 lpm (17,7 gpm)
Water Tank Capacity	: 650 lt (171 gal) and Hose 15 m (49' 2")
Lubrication System	: Electrically Controlled Central System (LINCOLN)
Driven by	: Gear Box (Stiebel)

BOOM SYSTEM

Boom Type	: RZ
Sections	: 5
Boom Swing Time	: 194 sec
Boom Swinging Angle	: 365°
Concrete Pipe Diameter	: 125 mm (4,92")

SUPPORT LEGS SYSTEM

Front Legs	: X
Rear Legs	: Side Hydraulic Swing

CONTROL SYSTEM

- Smartstar Control
- Color LCD
- IP69K Electronic Keypad
- Diagnostic
- Fuel Saving Mode
- 2nd Back up Radio Remote and Receiver

OPTIONS

- Hopper Vibrator
- Hydraulic Driven Fan
- Stability Control
- Air Compressor
- End Hose Squeeze Valve
- High Pressure Cleaning Kit (160 bar / 2320 psi)
- Betonstar IoT System
- Tool Boxes (If space is available)
- Water and Oil Tank Heater
- Leg Fuel Tank

BOOM WORKING DIAGRAM

