

BSS 36.000

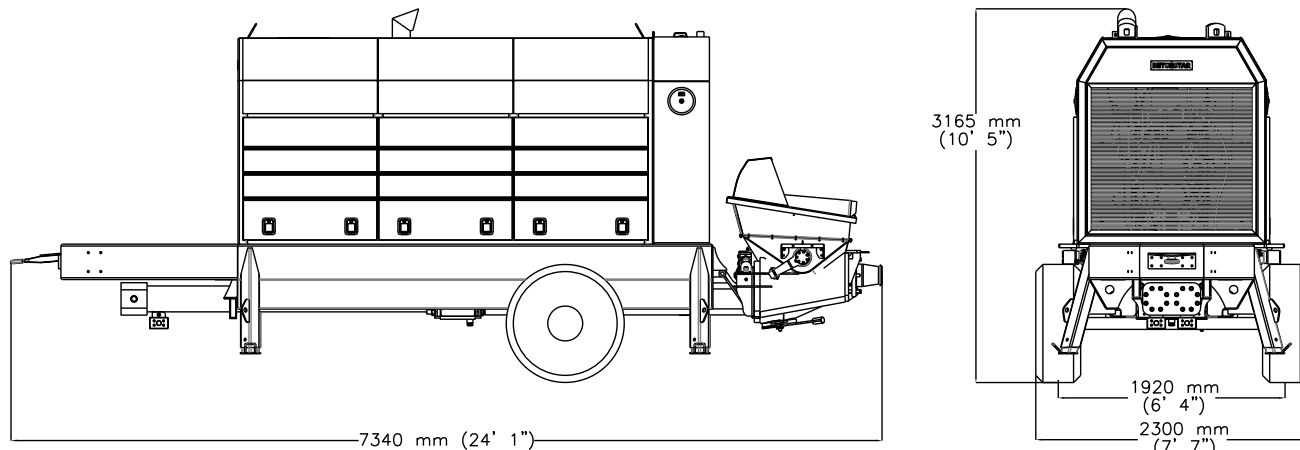

General

Weight : 10.500 kg (13.148 lbs)

Engine*

Power : 515 kW (700 hp) (Diesel)

Pumping Unit

Rod side	Theo. Conc. Output(max)	: 103 m ³ /h (134,71 y3/h)
	Theo. Conc. Pressure(max)	: 153 bar (2219,08 psi)
	Stroke	: 27 Stroke / min
Piston side	Theo. Conc. Output(max)	: 74 m ³ /h (96,78 y3/h)
	Theo. Conc. Pressure(max)	: 224 bar (3248,84 psi)
	Stroke	: 19 Stroke / min
Concrete Valve	: S Valve System	
Main Hydraulic Pump	: 2 x A4 VG 180 Tandem (RETROTH)	
Switch-Over Pressure S-Tube	: 190 bar (2755,7 psi)	
Delivery Cylinders Diameter	: 200 mm (7,87")	
Delivery Cylinders Stroke	: 2100 mm (82,68")	
Hopper Capacity	: 650 l (171,71 gal)	
Hopper Outlet Diameter	: 125 mm (5")	
Lateral Output Pipeline	: 150 mm (6")	
Switching System	: Elect. Magn. Sensor	
Lubrication System	: Hydraulic (LINCOLN)	
Electric Box	: Waterproof and PLC Controlled	

Control

- Smartstar Control
- Color LCD
- Diagnostic
- Fuel Saving Mode
- Remote Control

Options

- Hopper Vibrator
- Hydraulic Driven Fan
- Betonstar IoT System
- Remote Control (HBC)
- Air Compressor
- High Pressure Cleaning Kit (140 bar / 2030 psi)
- Water Pump (67 lpm / 17,7 gpm)
- Water Tank Capacity (500 l / 132 gal and Hose 15 m / 49' 2")

(*) Engine power and norm values vary according to the engine brand.