

**AS 32 – 4Z**

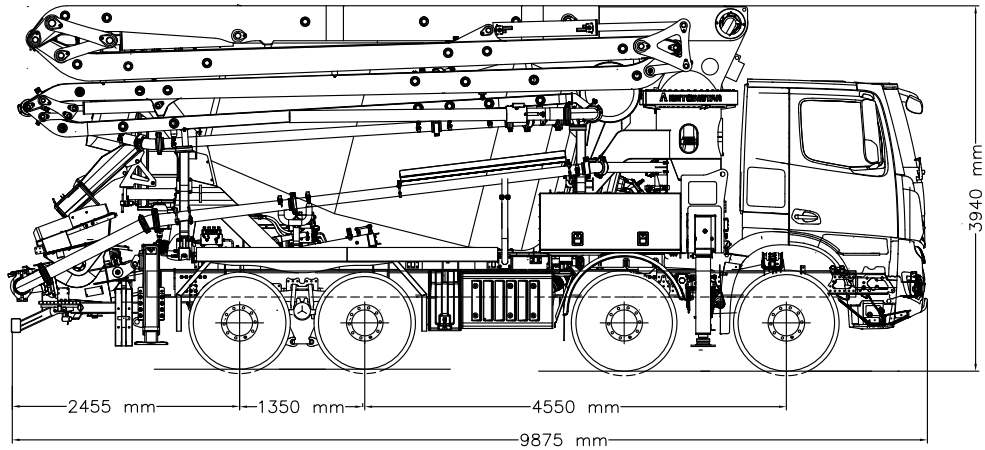

Note : Dimensions may vary depending on truck model.

AS 32.70 4Z	
<b>PUMP GROUP</b>	Standard
Theo. Conc. Output (max) (Piston Side)	70 m <sup>3</sup> / h
Theo. Conc. Pressure (max) (Piston Side)	81 bar
Stroke	28 Stroke / min
Concrete Cylinder Dimensions	230 mm x 1000 mm
<b>STANDARD EQUIPMENT</b>	
Hopper Capacity	: 450 l
Switching System	: Elect. Magn. Sensor
Concrete Valve	: S Valve System
Electric Box	: Waterproof and PLC Controlled
Remote Control	: Included (HETRONIC)
End Hose	: 3 m
Water Tank Capacity	: 500 l and Hose 15 m (Pressure Tank)
Lubrication System	: Hydraulic (LINCOLN)
Driven by	: PTO or Gear Box
<b>BOOM SYSTEM</b>	
Boom Type	: 4Z
Sections	: 4
Boom Swing Time	: 104 sec
Boom Swinging Angle	: 365°
Concrete Pipe Diameter	: 100 mm
<b>SUPPORT LEGS SYSTEM</b>	
Front Legs	: X
Rear Legs	: Fixed
<b>MIXER SYSTEM</b>	
Nominal Capacity	: 9 m <sup>3</sup>
Drum Speed	: 1-13 rpm
Filling Ratio	: 73%
<b>CONTROL SYSTEM</b>	
■ Smartstar Control	
■ Color LCD	
■ Rear Keyboard	
■ Diagnostic	
■ Fuel Saving Mode	
<b>OPTIONS</b>	
■ Hopper Vibrator	
■ Hydraulic Driven Fan	
■ Stability Control	
■ Air Compressor	
■ End Hose Squeeze Valve	
■ High Pressure Cleaning Kit (140 bar)	
■ Betonstar IoT System	
■ Remote Control (HBC)	
■ Auto Unfolding	
■ Water and Oil Tank Heater	
■ Water Pump (Hydraulic Operated)	

**BOOM WORKING DIAGRAM**

