

BST 24 – 4ZR

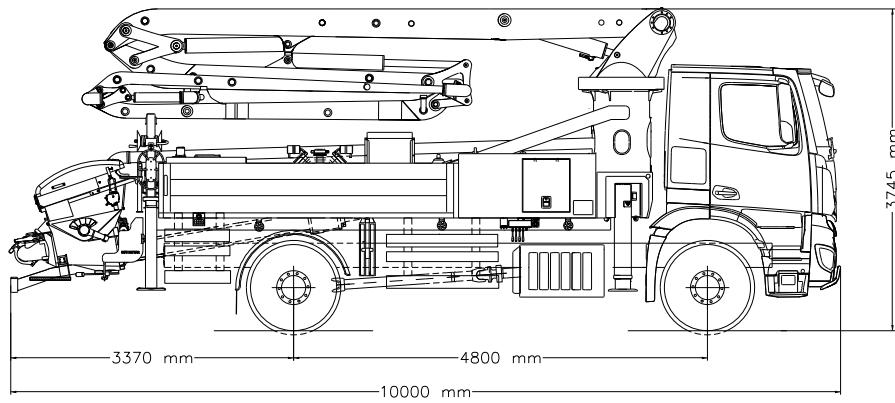

Note : Standard version model is BST 24.90 4ZR.

Dimensions may vary depending on truck model.

	BST 24.90 4ZR	BST 24.14S 4ZR	BST 24.16S 4ZR
PUMP GROUP	Standard	Optional	Optional
Theo. Conc. Output (Piston Side)	90 m ³ / h	140 m ³ / h	160 m ³ / h
Theo. Conc. Pressure (Piston Side)	81 bar	81 bar	81 bar
Stroke	26 Stroke / min	29 Stroke / min	29 Stroke / min
Concrete Cylinder Dimensions	230 mm x 1400 mm	230 mm x 1900 mm	250 mm x 1900 mm

STANDARD EQUIPMENT

Hopper Capacity	: 650 l
Switching System	: Elect. Magn. Sensor
Concrete Valve	: S Valve System
Electric Box	: Waterproof and PLC Controlled
Remote Control	: Included (HETRONIC)
End Hose	: 3 m
Water Pump	: 67 lpm
Water Tank Capacity	: 500 l and Hose 15 m
Lubrication System	: Hydraulic (LINCOLN)
Driven by	: PTO or Gear Box

BOOM SYSTEM

Boom Type	: 4ZR
Sections	: 4
Boom Swing Time	: 104 sec
Boom Swinging Angle	: 365°
Concrete Pipe Diameter	: 125 mm

SUPPORT LEGS SYSTEM

Front Legs	: X
Rear Legs	: Fixed

CONTROL SYSTEM

- Smartstar Control
- Color LCD
- Rear Keyboard
- Diagnostic
- Fuel Saving Mode

OPTIONS

- Hopper Vibrator
- Hydraulic Driven Fan
- Stability Control
- Air Compressor
- End Hose Squeeze Valve
- High Pressure Cleaning Kit (140 bar)
- Side Box
- Betonstar IoT System
- Remote Control (HBC)
- Auto Unfolding
- Water and Oil Tank Heater

BOOM WORKING DIAGRAM

