

**BST 30 – 4Z**

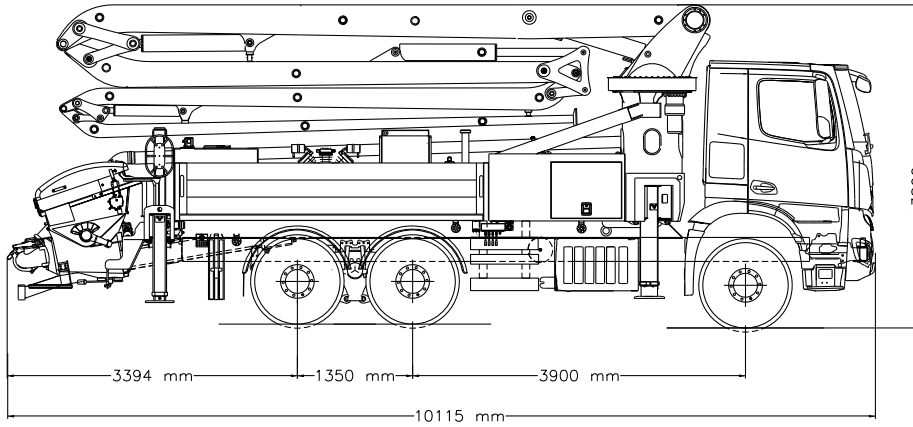

Note : Standard pump model is BST 30.90 4Z.

Dimensions may vary depending on truck model.

	BST 30.90 4Z	BST 30.14S 4Z	BST 30.16S 4Z
<b>PUMP GROUP</b>	Standard	Optional	Optional
Theo. Conc. Output (Piston Side)	90 m <sup>3</sup> / h	140 m <sup>3</sup> / h	160 m <sup>3</sup> / h
Theo. Conc. Pressure (Piston Side)	81 bar	81 bar	81 bar
Stroke	26 Stroke / min	29 Stroke / min	29 Stroke / min
Concrete Cylinder Dimensions	230 mm x 1400 mm	230 mm x 1900 mm	250 mm x 1900 mm

**STANDARD EQUIPMENT**

Hopper Capacity	: 650 l
Switching System	: Elect. Magn. Sensor
Concrete Valve	: S Valve System
Electric Box	: Waterproof and PLC Controlled
Remote Control	: Included (HETRONIC)
End Hose	: 3 m
Water Pump	: 67 lpm
Water Tank Capacity	: 650 l and Hose 15 m
Lubrication System	: Hydraulic (LINCOLN)
Driven by	: PTO or Gear Box

**BOOM SYSTEM**

Boom Type	: 4Z
Sections	: 4
Boom Swing Time	: 104 sec
Boom Swinging Angle	: 365°
Concrete Pipe Diameter	: 125 mm

**SUPPORT LEGS SYSTEM**

Front Legs	: X
Rear Legs	: Sliding Support

**CONTROL SYSTEM**

- Smartstar Control
- Color LCD
- Rear Keyboard
- Diagnostic
- Fuel Saving Mode

**OPTIONS**

- Hopper Vibrator
- Hydraulic Driven Fan
- Stability Control
- Air Compressor
- End Hose Squeeze Valve
- High Pressure Cleaning Kit (140 bar)
- Side Box
- Betonstar IoT System
- Remote Control (HBC)
- Auto Unfolding
- Water and Oil Tank Heater

**BOOM WORKING DIAGRAM**

