

BST 37 – 5Z

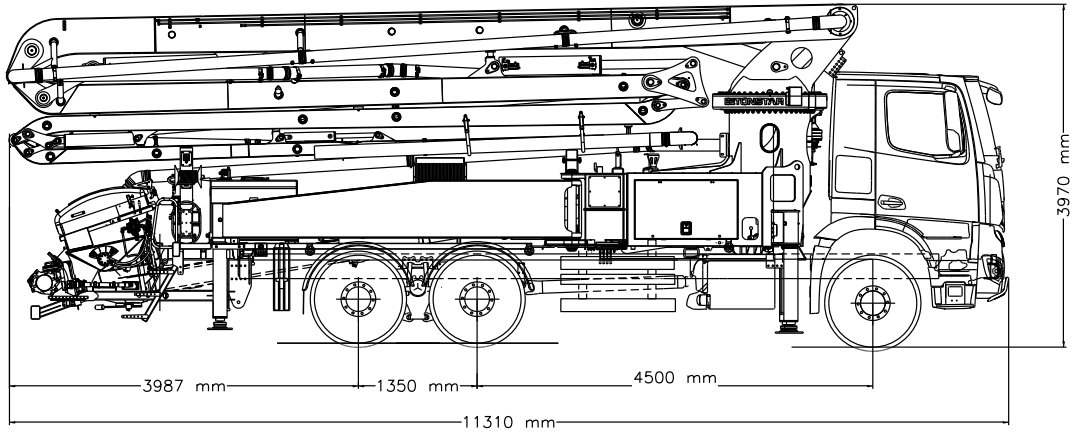

Note : Dimensions may vary depending on truck model.

BST 37.14 5Z	
PUMP GROUP	Standard
Theo. Conc. Output (max) (Rod Side)	140 m ³ / h
Theo. Conc. Pressure (max) (Rod Side)	69 bar
Stroke	26 Stroke / min
Concrete Cylinder Dimensions	230 mm x 2100 mm

STANDARD EQUIPMENT	
Hopper Capacity	: 650 l
Switching System	: Elect. Magn. Sensor
Concrete Valve	: S Valve System
Electric Box	: Waterproof and PLC Controlled
Remote Control	: Included (HETRONIC)
End Hose	: 3 m
Water Pump	: 67 lpm
Water Tank Capacity	: 650 l and Hose 15 m
Lubrication System	: Hydraulic (LINCOLN)
Driven by	: PTO or Gear Box

BOOM SYSTEM	
Boom Type	: 5Z
Sections	: 5
Boom Swing Time	: 113 sec
Boom Swinging Angle	: 365°
Concrete Pipe Diameter	: 125 mm

SUPPORT LEGS SYSTEM	
Front Legs	: X
Rear Legs	: Side Hydraulic Swing

CONTROL SYSTEM	
■ Smartstar Control	
■ Color LCD	
■ Rear Keyboard	
■ Diagnostic	
■ Fuel Saving Mode	

OPTIONS	
■ Hopper Vibrator	
■ Hydraulic Driven Fan	
■ Stability Control	
■ Air Compressor	
■ End Hose Squeeze Valve	
■ High Pressure Cleaning Kit (140 bar)	
■ Betonstar IoT System	
■ Remote Control (HBC)	
■ Auto Unfolding	
■ Water and Oil Tank Heater	

BOOM WORKING DIAGRAM

