

**BST 37 – 5Z**

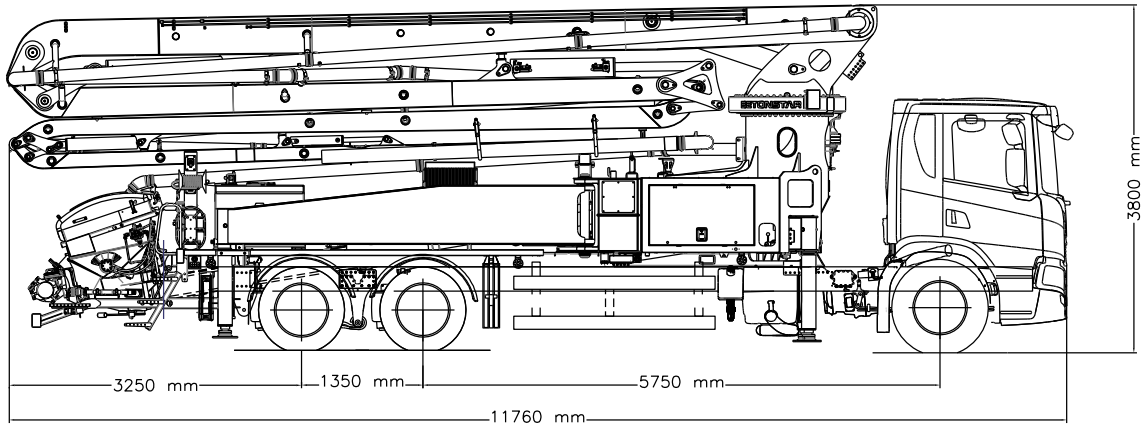

Note : Dimensions may vary depending on truck model.

Pump	BST 37.14H 4Z
Theo. Conc. Output(max) (Piston Side)	140 m <sup>3</sup> / h
Theo. Conc. Pressure(max) (Piston Side)	81 bar
Stroke	26 Stroke / min
Concrete Cylinder Dimensions	230 mm x 2100 mm

**Standard Equipments**

Hopper Capacity	: 650 liter
Switching System	: Elect. Magn. Sensor
Concrete Valve	: S, Valve System
Electric Box	: Waterproof and PLC controlled
Remote Control	: Included (HETRONIC)
End Hose	: 3 m
Water Pump	: 67 lpm
Water Tank Capacity	: 650 liter and hose 15 m
Lubrication System	: Hydraulic (LINCOLN)
Driven by	: PTO or gear box

**Boom System**

Boom Type	: 5Z
Sections	: 5
Boom Swing Speed	: 113 sec
Boom Swinging Angle	: 365°
Concrete Pipe Diameter	: 125 mm

**Support Leg System**

Front Legs	: X
Rear Legs	: Side Hydraulic Swing

**Control System**

- Smartstar Control
- Color LCD
- Rear Keyboard
- Diagnostic
- Fuel Saving Mode

**Options**

- Hopper vibrator
- Hydraulic driven fan
- Stability control
- Air compressor
- End hose squeezer
- High pressure cleaning kit (140 bar)
- Betonstar IoT system
- Remote control(HBC)
- Auto unfolding
- Water and oil tank heater

**Diagrams**

