

BST 40 – 5RZ

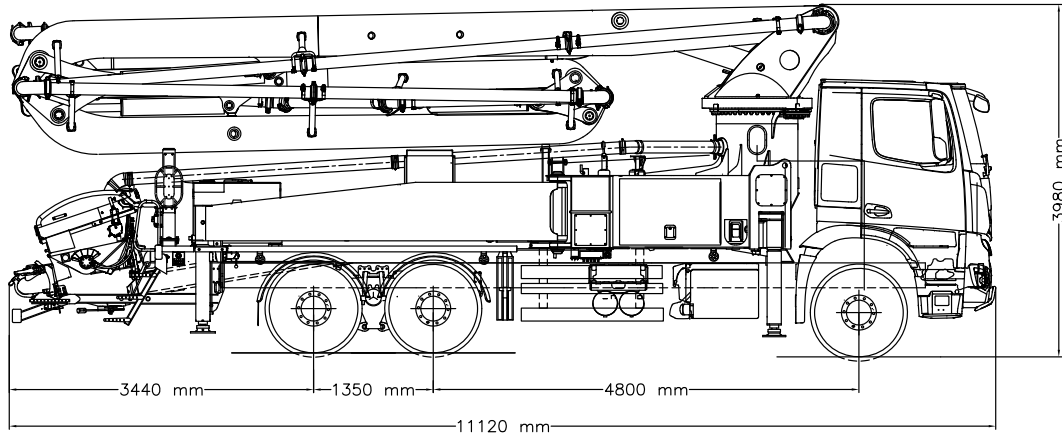

Note : Standard pump model is BST 40.14H 5RZ.

Dimensions may vary depending on truck model.

| | BST 40.14H 5RZ | BST 40.16 5RZ |
|--|-----------------------|-----------------------|
| PUMP GROUP | Standard | Optional |
| Theo. Conc. Output (max) (Piston Side) | 140 m ³ /h | 160 m ³ /h |
| Theo. Conc. Pressure (max) (Piston Side) | 81 bar | 81 bar |
| Stroke | 26 Stroke / min | 26 Stroke / min |
| Concrete Cylinder Dimensions | 230 mm x 2100 mm | 250 mm x 2100 mm |

STANDARD EQUIPMENT

| | |
|---------------------|---------------------------------|
| Hopper Capacity | : 650 l |
| Switching System | : Elect. Magn. Sensor |
| Concrete Valve | : S Valve System |
| Electric Box | : Waterproof and PLC Controlled |
| Remote Control | : Included (HETRONIC) |
| End Hose | : 3 m |
| Water Pump | : 67 lpm |
| Water Tank Capacity | : 650 l and Hose 15 m |
| Lubrication System | : Hydraulic (LINCOLN) |
| Driven by | : PTO or Gear Box |

BOOM SYSTEM

| | |
|------------------------|-----------|
| Boom Type | : 5RZ |
| Sections | : 5 |
| Boom Swing Time | : 113 sec |
| Boom Swinging Angle | : 365° |
| Concrete Pipe Diameter | : 125 mm |

SUPPORT LEGS SYSTEM

| | |
|------------|------------------------|
| Front Legs | : X |
| Rear Legs | : Side Hydraulic Swing |

CONTROL SYSTEM

| |
|---------------------|
| ■ Smartstar Control |
| ■ Color LCD |
| ■ Rear Keyboard |
| ■ Diagnostic |
| ■ Fuel Saving Mode |

OPTIONS

| |
|--|
| ■ Hopper Vibrator |
| ■ Hydraulic Driven Fan |
| ■ Stability Control |
| ■ Air Compressor |
| ■ End Hose Squeeze Valve |
| ■ High Pressure Cleaning Kit (140 bar) |
| ■ Betonstar IoT System |
| ■ Remote Control (HBC) |
| ■ Auto Unfolding |
| ■ Water and Oil Tank Heater |

BOOM WORKING DIAGRAM

