

BST 51 – 5RZ

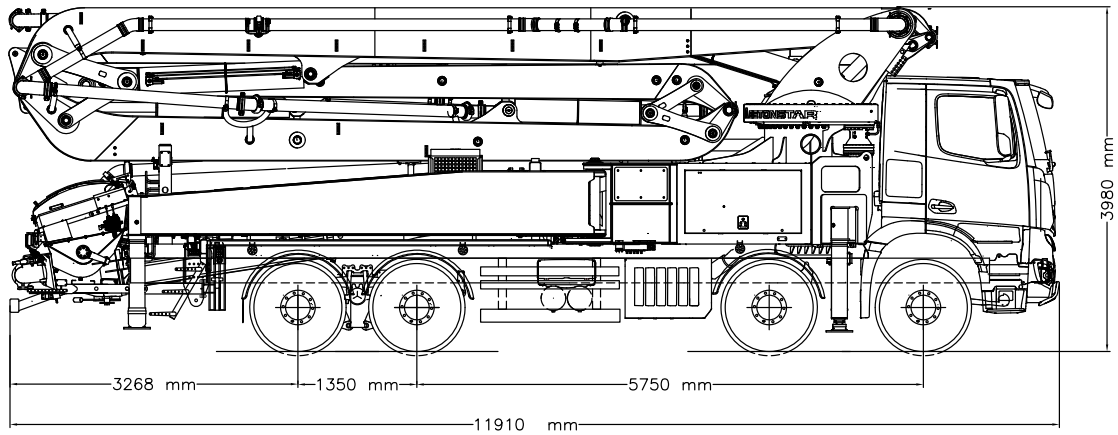

Note : Standard pump model is BST 51.16 5RZ.

Dimensions may vary depending on truck model.

	BST 51.16 5RZ	BST 51.20 5RZ
PUMP GROUP	Standard	Optional
Theo. Conc. Output (max) (Piston Side)	160 m ³ / h	200 m ³ / h
Theo. Conc. Pressure (max) (Piston Side)	81 bar	81 bar
Stroke	26 Stroke / min	27 Stroke / min
Concrete Cylinder Dimensions	250 mm x 2100 mm	250 mm x 2500 mm

STANDARD EQUIPMENT

Hopper Capacity	: 650 l
Switching System	: Elect. Magn. Sensor
Concrete Valve	: S Valve System
Electric Box	: Waterproof and PLC Controlled
Remote Control	: Included (HETRONIC)
End Hose	: 3 m
Water Pump	: 67 lpm
Water Tank Capacity	: 650 l and Hose 15 m
Lubrication System	: Hydraulic (LINCOLN)
Driven by	: PTO or Gear Box

BOOM SYSTEM

Boom Type	: 5RZ
Sections	: 5
Boom Swing Time	: 240 sec
Boom Swinging Angle	: 365°
Concrete Pipe Diameter	: 125 mm

SUPPORT LEGS SYSTEM

Front Legs	: X
Rear Legs	: Side Hydraulic Swing

CONTROL SYSTEM

■ Smartstar Control
■ Color LCD
■ Rear Keyboard
■ Diagnostic
■ Fuel Saving Mode

OPTIONS

■ Hopper Vibrator
■ Hydraulic Driven Fan
■ Stability Control
■ Air Compressor
■ End Hose Squeeze Valve
■ High Pressure Cleaning Kit (140 bar)
■ Betonstar IoT System
■ Remote Control (HBC)
■ Water and Oil Tank Heater

BOOM WORKING DIAGRAM

